

KALKAREA



CERAMICHE
SUPERGRES

Welcome to Factory Fast by IWT

Featuring Kalkarea Collection

Supergres and IWT have entered into a strategic partnership for the distribution of Kalkarea, beautiful interpretation of a limestone available in many sizes and finishes.

Explore the collections, designed to meet the highest standards of quality and innovation, delivered to your door by IWT's renowned service

For more information please contact us

e; info@iwttesororo.com

p: (772) 223-5151

CERAMICHE
SUPERGRES





NORTHERN LIGHTS

La luce a queste latitudini accarezza e non scolpisce, crea atmosfere tenui, si riflette sulle superfici luminose, dai colori neutri e naturali, amplificandosi all'interno degli ambienti. Lo stile riflette l'armonia e la bellezza della natura con un design essenziale e pulito, che esalta l'atmosfera creando ambienti dal fascino moderno ed elegante.

Light at these latitudes caresses rather than sculpts, it creates soft atmospheres and is reflected on bright surfaces in neutral, natural colours and amplifies indoors. The style reflects the harmony and beauty of nature with an essential, neat design that enhances the atmosphere, creating rooms with a modern and elegant charm.

La lumière de ces latitudes caresse et ne façonne pas, crée des atmosphères douces, se reflète sur les surfaces lumineuses, aux couleurs neutres et naturelles, en s'amplifiant à l'intérieur des espaces. Le style reflète l'harmonie et la beauté de la nature avec un design essentiel et épuré, qui met en valeur l'atmosphère en créant des espaces au charme moderne et élégant.

Das Licht in diesen Breitengraden formt nicht, sondern schmiegt, es schafft gedämpfte Atmosphären, wird auf leuchtenden Oberflächen in neutralen, natürlichen Farben reflektiert und verstärkt sich im Raum. Der Stil spiegelt die Harmonie und die Schönheit der Natur mit einem essentiellen, klaren Design wider, das die Atmosphäre aufwertet und Räume mit einem modernen und eleganten Charme schafft.

PEARL
WHITE
IVORY
SAND

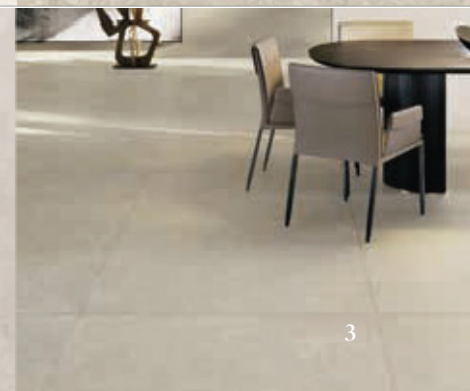
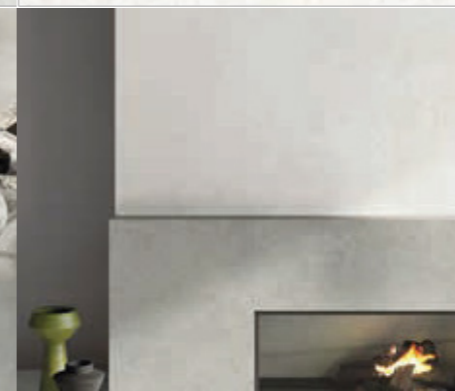







KALKAREA

Gres Porcelanato
Porcelain Stoneware
Grès cérame
Feinsteinzeug

Factory Fast stock availability chart

SIZES

 120 x 278 RT 48" x 109 1/2"	 120 x 120 RT 48" x 48"	 60 x 120 RT 24" x 48"	 60 x 60 RT 24" x 24"	 30 x 60 RT 12" x 24"	 SHAPE 30,5x30,8 12" x 12"
--	---	---	--	--	---

WHITE	○	■ ●	■ ● T-20	■ ● T-20	■ ● ■
IVORY	○	■ ●	■ ● T-20	■ ● T-20	■ ● ■
SAND		■ ●	■ ●	■ ●	■ ● ■
PEARL		■ ●	■ ● T-20	■ ● T-20	■ ● ■

“Ceramics of Italy”



STOCKED IN

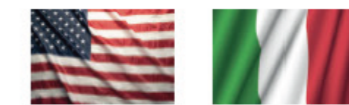

FINISHES

■	■	R10 B ANTI SLIP SOFT TOUCH thick 9mm
○	○	LASTRA thick 6mm
●	●	GRIP R11 C thick 9mm
T-20	T-20	R11 C thick 20mm

IVORY

Armonioso ed elegante, riscalda ogni ambiente con le sue note calde.

Harmonious and elegant, it warms any room with its warm notes.

Harmonieuse et élégante, elle réchauffe chaque espace avec ses notes chaudes.

Harmonisch und elegant erwärmt dieses Produkt jeden Raum mit seinen warmen Noten.



Kalkarea ivory 120x120RT - 48"x48"
Kalkarea ivory 120x278RT - 48"x109 1/2"

IVORY



Kalkarea ivory 120x120RT - 48"x48"

Kalkarea ivory 120x278RT - 48"x109 1/2"

IVORY SAND



Kalkarea ivory T_20 60x120RT - 24"x48"
Kalkarea sand 60x120RT - 24"x48"

SAND

Pattern naturale e tenue, dal fondo caldo per atmosfere familiari.

Natural, soft pattern with a warm background, for familiar atmospheres.

Formes naturelles et douces sur fond chaud pour des atmosphères familiales.

Natürliches, weiches Muster mit einem warmen Untergrund für familiäre Atmosphären.



Kalkarea sand 120x120RT - 48"x48" Kalkarea
ivory mos.shape 30.5x30.8 - 12"x12"

SAND IVORY



Kalkarea sand 120x120RT - 48"x48"

Kalkarea sand 120x120RT - 48"x48"
Kalkarea ivory 120x278RT - 48"x109 1/2"

WHITE

Riflette dolcemente la luce naturale dando vita ad ambienti luminosi.

It gently reflects natural light, creating bright environments.

Reflète tendrement la lumière naturelle pour créer des espaces lumineux.

Es reflektiert sanft das natürliche Licht und schafft helle Umgebungen.



Kalkarea pearl 120x120RT - 48"x48" Kalkarea pearl grip 120x120RT - 48"x48" Kalkarea white 120x278RT - 48"x109 1/2" Love Brown nest 50x120RT - 20"x48" serie Colovers



WHITE PEARL



Kalkarea pearl 120x120RT - 48"x48"

Kalkarea white 120x278RT - 48"x109 1/2"

PEARL

Sfumature di colore moderne che esaltano arredi minimal tanto residenziali quanto commerciali.

Modern colour shades that enhance minimalist residential as well as commercial furnishing.

Des nuances de couleur modernes qui mettent en valeur des ameublements minimalistes, aussi bien résidentiels que commerciaux.

Moderne Farbnuancen unterstreichen minimalistische Wohn- und Geschäftseinrichtungen.



Kalkarea pearl 120x120RT - 48"x48"
Kalkarea pearl T20 60x120 - 24"x48"
Kalkarea white 120x278RT - 48"x109 1/2"

PEARL



Kalkarea pearl 120x120RT - 48"x48"

Kalkarea pearl T20 60x120RT - 24"x48"
Kalkarea white 120x278RT - 48"x109 1/2"



PEARL





Kalkarea pearl T20 60x120RT - 24"x 48"

Kalkarea pearl T20 60x120RT - 24"x 48"

KALKAREA

Gres Porcellanato
Porcelain stoneware | Grès cérame | Feinsteinzeug

9 mm  anti slip soft touch R10 B | 120x120 RT, 60x120 RT, 60x60 RT, 30x60 RT
9 mm  grip R11 C* | 120x120 RT, 60x120 RT, 60x60 RT, 30x60 RT
20 mm  T20 R11 C | 60x120 RT, 60x60 RT





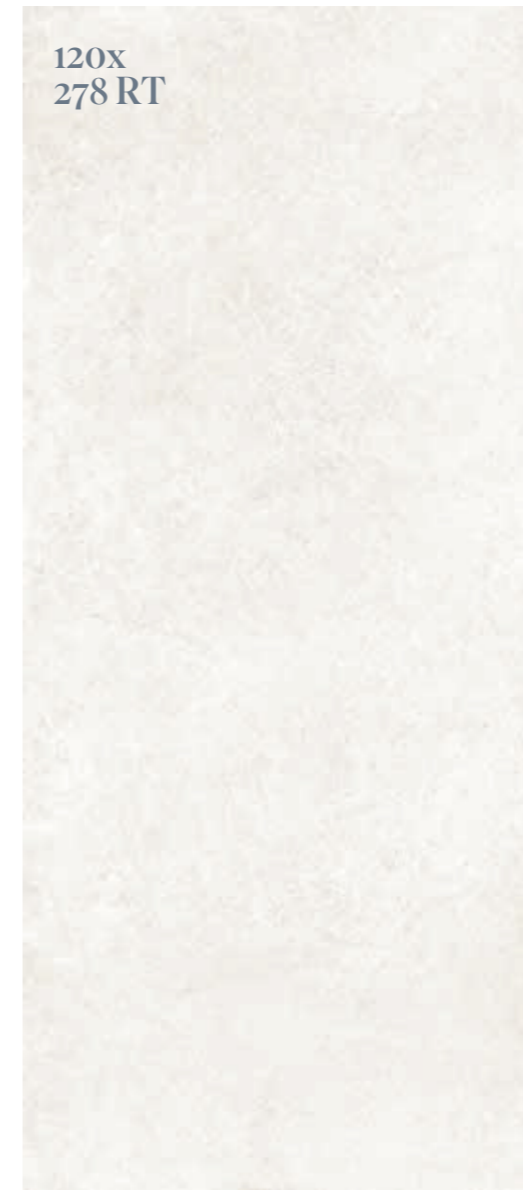

6 mm  120x278 RT 9 mm | anti slip soft touch R10 B | 120x120 RT, 60x120 RT, 60x60 RT, 30x60 RT 9 mm | grip R11 C* | 120x120 RT, 60x120 RT, 60x60 RT, 30x60 RT





*disponibile su richiesta / available upon request

KALKAREA

Gres Porcellanato Porcelain stoneware | Grès cérame
| Feinsteinzeug

- 6 mm  120x278 RT
- 9 mm  anti slip soft touch R10 B | 120x120 RT, 60x120 RT, 60x60 RT, 30x60 RT
- 9 mm  grip R11 C* | 120x120 RT, 60x120 RT, 60x60 RT, 30x60 RT
- 20 mm  T20 R11 C | 60x120 RT, 60x60 RT



- 9 mm  grip R11 C* | 120x120 RT, 60x120 RT, 60x60 RT, 30x60 RT
- 9 mm  anti slip soft touch R10 B | 120x120 RT, 60x120 RT, 60x60 RT, 30x60 RT



*disponibile su richiesta / available upon request

KALKAREA

Gres Porcellanato
Porcelain stoneware | Grès cérame | Feinsteinzeug

T.20

Kalkarea è disponibile anche nella versione strutturata antiscivolo in 20 mm di spessore, nei formati 60x60 e 60x120 rettificati. Garantisce una perfetta continuità estetica tra l'interno e l'esterno, e la sicurezza di utilizzare un materiale altamente resistente che mantiene inalterate nel tempo le proprie caratteristiche.

Kalkarea is also available in the anti-slip version in 20 mm thickness, in the rectified sizes 60x60 and 60x120. This guarantees perfect aesthetic continuity between the interior and exterior, and the security of using a highly resistant material that maintains its technical and aesthetic characteristics over time.

Disponible aussi dans la version structurée antidérapante en 20 mm d'épaisseur, dans les formats 60x60 et 60x120 rectifiés, Kalkarea garantit une parfaite continuité esthétique entre l'intérieur et l'extérieur, et la sécurité d'utiliser un matériau hautement résistant qui conserve inaltérées ses caractéristiques.

Erhältlich auch in der strukturierten, rutschfesten Version in 20 mm Stärke, in den rektifizierten Formaten 60x60 und 60x120, garantiert er eine perfekte ästhetische Kontinuität zwischen Innen- und Außenbereich und die Sicherheit, ein sehr widerstandsfähiges Material zu verwenden, das seine Eigenschaften im Laufe der Zeit unverändert beibehält.

20 mm  T20 R11 C | 60x120 RT, 60x60 RT

PEARL T₂₀

60x
120 RT

60x
60 RT

IVORY T₂₀

60x 120
RT

60x
60 RT



Kalkarea ivory 120x278RT - 48"x109 1/2"
Kalkarea ivory T20 60x120RT - 24"x 48"

KALKAREA

Gres Porcellanato
Porcelain stoneware | Grès cérame | Feinsteinzeug

MOSAICO SHAPE

Il mosaico esagonale crea un originale disegno sulla parete.

The hexagonal mosaic creates an unique texture on the wall. La mosaïque hexagonale crée un un dessin original sur le mur. Das sechseckige Mosaik schafft Bewegung an der Wand.



30,5x30,8
PEARL



30,5x30,8
WHITE



30,5x30,8
IVORY



30,5x30,8
SAND

MOSAICO

Il mosaico con tessera quadrata decora gli ambienti con semplicità.

The mosaic with square tile decorates your spaces with simplicity. La mosaïque carrée décore les espaces avec simplicité. Das Mosaik mit quadratischen Fliesen schmückt die Räume mit Einfachheit.

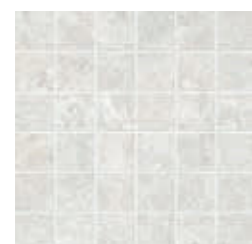

30x30 RT
PEARL

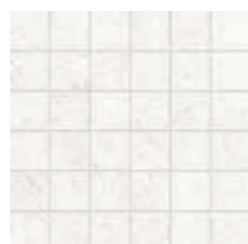

30x30 RT
WHITE

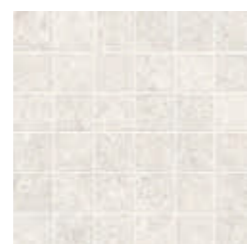

30x30 RT
IVORY



30x30 RT
SAND



Kalkarea mos. shape 30,5x30,8 - 12"x12"

KALKAREA

Gres Porcellanato
 PEZZI SPECIALI PER GRADINI E BATTISCOPA
 PEZZI SPECIALI PER GRADINI E BATTISCOPA | FORMTEILE

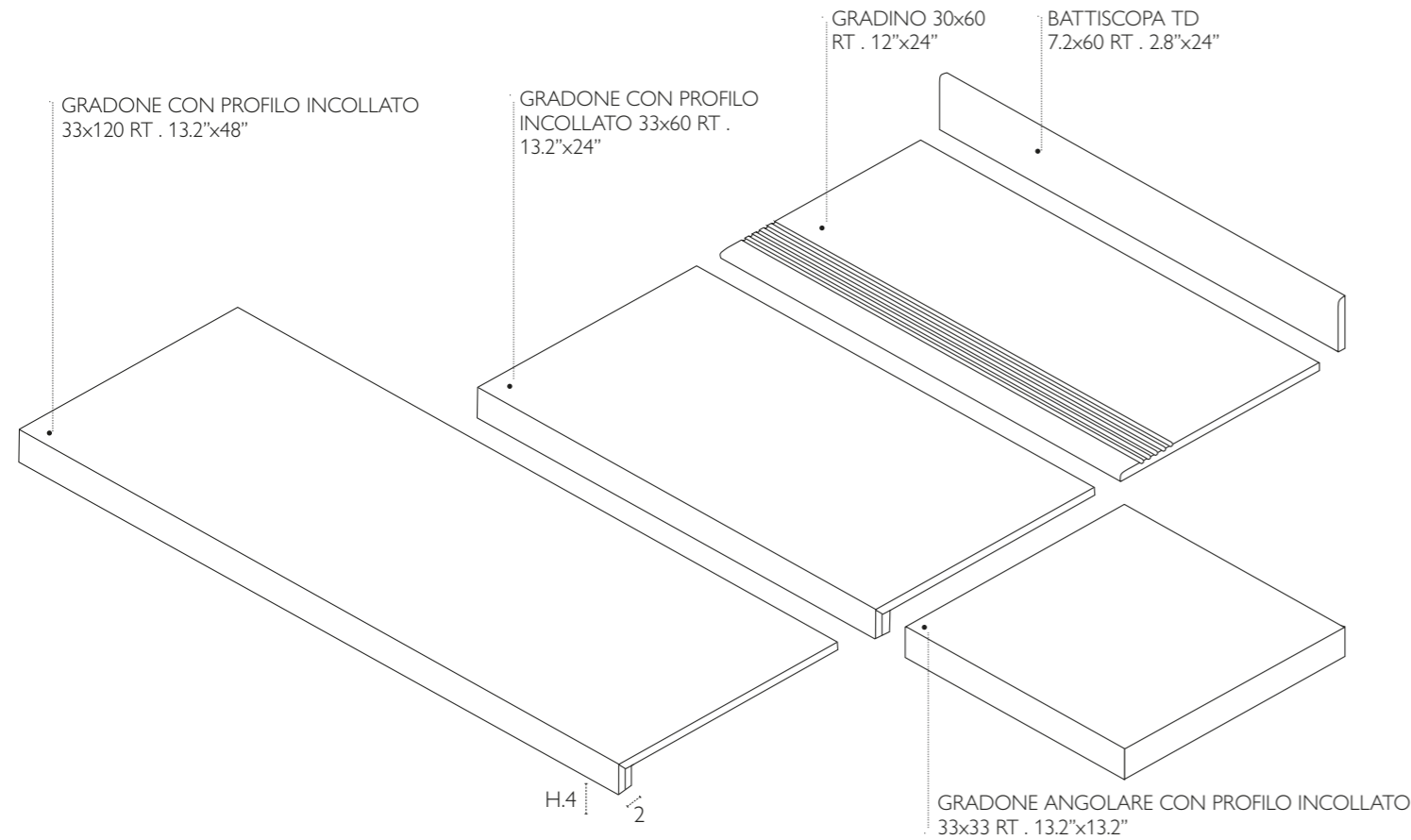

PEZZI SPECIALI DISPONIBILI SU TUTTI I COLORI, SU ORDINAZIONE. TRIM TILES AVAILABLE IN ALL COLORS TO ORDER.
 PIÈCES SPÉCIALES DISPONIBLES DANS TOUTES LES COULEURS, SUR DEMANDE. FORMTEILE AUF BESTELLUNG IN ALLEN FARBEN VERFÜGBAR.

IMBALLI | EMBALLAGE | VERPACKUNG | PACKING

	pz/box	mq/box	kg/box	box/plt	mq/plt	kg/plt	spessore
120x278RT a / crate cm291,6x144,5x33,8 kg 88	1	3,34	49,50	18	60,05	979	6 mm
*120x278 fornito in casse di dimensioni 291,6x144,5x33,8 (PxLxH) cm - Peso kg 88 / o in casse per max 5 pz. dim.291,6x144,5x24h - peso kg 52,5 * 120x278 supplied in crates. Dimensions crate cm 291,6x144,5x33,8h cm - Weight kg 88 / crates 5 pcs (charge max). Dim.291,6x144,5x24h - Weight kg 52,5							
120x278RT cassa leggera (max 5pz) cm 291,6x144,5x24 kg 54	1	3,34	49,50	5	16,68	301	6 mm
120x278RT cavalletto / stand containing (18pz) (carico max / charge max 42pz)	1	3,34	49,50	18	60,05	1051	6 mm
** 120x278 fornito su cavalletti (18 pz o 42 pz - carico max) di dimensioni 290x75x156 (PxLxH) cm - Peso kg 160 ** 120x278 supplied in stand containing (18 pcs or 42 pcs - charge max). Dimensions cm 290x75x156h cm - Weight kg 160							
	pz/box	mq/box	kg/box	box/plt	mq/plt	kg/plt	spessore
120X120RT / 120x120RT GRIP	2	2,88	60,00				
		20	57,60				
		1212	9 mm				
60X120RT / 60X120RT GRIP	2	1,44	30,00	35	50,40	1062	9 mm
60x60RT / 60X60RT GRIP	3	1,08	22,00	40	43,20	892	9 mm
30x60 RT / 30X60RT GRIP	7	1,26	25,00	40	50,40	1012	9 mm
mosaico 30x30RT	10	0,90	16,00	30	27,00	495	9 mm
mosaico shape 30,5x30,8	6	0,56	9,00	--			9 mm
battiscopa 7,2x60	10	6,00 ml	9,00	70	420 ml	645	
gradone c/p inc. 33X120RT	2						
gradone c/p inc. 33X60RT	4					--	
angolare gradone c/p inc. 33X33RT	4						
gradino 30x60RT	7					--	

materiale rettificato si prescrive una fuga minima di 2 mm .As for rectified materials, a minimum joint of 2 mm is required . Pour la pose du matériau rectifié, il faut réaliser un joint minimum de 2 mm . Für die Verlegung des geschliffenen Materials ist eine Mindestfuge von 2 mm vorgeschrieben .

Si raccomanda di posare i materiali sfalsati di 20 cm al massimo, mai a metà della loro lunghezza . It is strongly recommended to install the materials in a staggered pattern of a maximum of 20 cm, never at half way its length . Il est conseillé de poser les matériaux en décalé de 20 cm au maximum, jamais à la moitié de leur longueur . Es wird empfohlen, die Materialien um höchstens 20 cm versetzt zu verlegen und nie in der Mitte ihrer Länge



KALKAREA

Gres Porcellanato
Porcelain stoneware | Grès cérame | Feinsteinzeug



Norma di riferimento: EN 14411 (ISO 13006) Allegato G - Piastrelle di ceramica pressate a secco con basso assorbimento d'acqua (Ev 0,5%) Norme retenue: EN 14411 (ISO 13006) Annexe G - Carreaux céramiques pressés à sec avec faible absorption d'eau (Ev ≤ 0,5%). Bezugsnorm: EN 14411 (ISO 13006) Anlage G - Trockengepresste keramische Fliesen und Platten mit niedriger Wasseraufnahme (Ev ≤ 0,5%). Reference standard: EN 14411 (ISO 13006) Appendix G - Dry pressed ceramic tiles with low water absorption (Ev ≤ 0,5%)

CARATTERISTICHE TECNICHE . TECHNICAL CHARACTERISTICS Características técnicas . Technische eigenschaften	NORMA NORMS Normes Normen	REQUISITI RICHIESTI . REQUIREMENTS Conditions requisés . Geforderte eigenschaften			VALORE MEDIO SUPERGRES * Valeur moyenne . Average rating		
		7 cm ≤ N < 15 cm	N ≥ 15 cm		SUPERFICIE NATURALE	SUPERFICIE GRIP	T20
Lunghezza e larghezza dei lati . Length and width of the sides Longuer et largeur de côtés . Länge und Breite	ISO 10545-2	± 0,4 mm	± 0,3 %	± 1,0 mm	Conforme . According to Conforme . Gemäss		
Rettilineità degli spigoli . Straightness Equerrage des angles . Kantengeradheit		± 0,4 mm	± 0,3 %	± 0,8 mm	Conforme . According to Conforme . Gemäss		
Ortogonalità** . Rectangularity** Orthogonalité . Rechtwinkligkeit		± 0,4 mm	± 0,3 %	± 1,5 mm	Conforme . According to Conforme . Gemäss		
Planarità . Flatness Planéité . Planität		± 0,6 mm	± 0,4 %	± 1,8 mm	Conforme . According to Conforme . Gemäss		
Spessore . Thickness Épaisseur . Stärke	ISO 10545-2	± 0,5 mm	± 5 %	± 0,5 mm	Conforme . According to Conforme . Gemäss		
Assorbimento % d'acqua . Water absorption Absorption d'eau . Wasseraufnahme	ISO 10545-3	Ev ≤ 0,5%			Conforme . According to Conforme . Gemäss		
Determinazione della resistenza a flessione e della forza di rottura Flexion and break resistance Résistance à la flexion et à la force de rupture Biegefestigkeit und Bruchlast	ISO 10545-4	Spessore ≥ 7,5 mm	S ≥ 1300 R ≥ 35 N / 2 mm		Conforme . According to Conforme . Gemäss		
Determinazione della resistenza all'abrasione profonda Deep Scratch Resistance Résistance à l'abrasion profonde Tiefenverschleissbeständigkeit	ISO 10545-6	≤ 175 mm			Conforme According to Conforme . Gemäss		
Coefficiente di espansione termica lineare tra 20° e 100° C Linear thermal expansion 20°C to 100°C Dilatation thermique linéaire entre 20°C et 100°C Lineare Waerme-ausdehnung zwischen 20°C und 100°C	ISO 10545-8	Metodo di prova disponibile . Test method available Méthode d'essai disponible . Prüfverfahren verfügbar			Conforme . According to Conforme . Gemäss		
Resistenza agli sbalzi termici . Thermal shock resistance Résistance aux écarts de Température . Temperaturwechselbeständigkeit	ISO 10545-9	Metodo di prova disponibile . Test method available Méthode d'essai disponible . Prüfverfahren verfügbar			Conforme . According to Conforme . Gemäss		
Resistenza al gelo . Frost resistance Résistance au gel . Frostbeständigkeit	ISO 10545-12	Metodo di prova disponibile . Test method available Méthode d'essai disponible . Prüfverfahren verfügbar			Conforme . According to Conforme . Gemäss		
Reazione al fuoco . Reaction to fire Réaction au feu . Brandverhalten		Classe A1 oppure A1fl - Class A1 or A1fl Categorie A1 ou A1fl - Klasse A1 oder A1fl			A1-A1fl		
Determinazione della resistenza chimica . Chemical resistance Résistance chimique . Chemikalienbeständigkeit	ISO 10545-13	Classe B mini mo Class B min Clase B Klasse B			A LA HA		
Determinazione della resistenza alle macchie . Resistance to staining Résistance aux taches . Beständigkeit gegen Fleckenbil	ISO 10545-14	Classe 3 minimo . Class 3 min Clase 3 min . Klasse 3 min			Conforme . According to Conforme . Gemäss		
Resistenza allo scivolamento . Slip resistance Résistance au glissement . Bestimmung der Rutschermungsfähigkeit	EN 16165 (previo DIN 51130)	Classificazione R . Classification R Evaluación R . Klassifizierung R			R10	R11	R11
Resistenza allo scivolamento - superfici bagnate calpestio a piedi scalzi Résistance au glissement - surfaces mouillées passage à pieds nus Bestimmung der Rutschermungsfähigkeit - nasse Oberfläche - Barfuß-gehen Coefficient of friction - dry surfaces walking on barefoot	EN 16165 (previo DIN 51097)	Classificazione A B C - Evaluación A B C Klassifizierung A B C - Classification A B C			A+B	A+B+C	A+B+C
Resistenza allo scivolamento - coefficiente di attrito dinamico (DCOF) Slip resistance - dynamic friction coefficient Résistance au glissement - coefficient de frottement dynamique Bestimmung der Rutschermungsfähigkeit - dynamischer reibungskoeffizient	ANSI A326.3	≥ 0,42			≥ 0,42	≥ 0,55	≥ 0,55
Metodo B.C.R.A D.M.I. Giugno 1989 n.236 (μ > 0,40)					Conforme . According to Conforme . Gemäss		

GRADO DI VARIAZIONE CROMATICA Ogni prodotto si caratterizza per un grado di stonizzazione variabile da prodotto a prodotto, da colore a colore. Per stonizzazione s'intende variazione di gradazione cromatica da piastrella a piastrella. COLOUR SHADE VARIATION Every product is characterised by colour-shading that can vary from one product to another and from one colour to another. When referring to the characteristics of the tile surface.

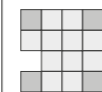

otto con leggera variazione cromatica
th a slight chromatic variation

LA CERAMIC A. UNA SCELTA SICURA. CERAMICS. A SAFE CHOICE.

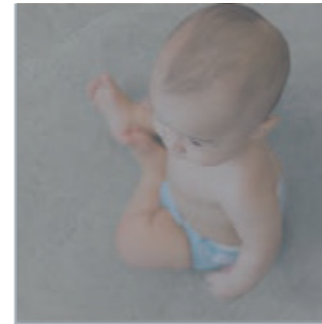

IGIENICA

La ceramica è facile da pulire, igienica e pratica; basta un semplice detergente neutro per rimuovere lo sporco e facilmente ritorna alla sua bellezza originaria.

HYGIENIC

Ceramic material is easy to clean, hygienic and practical; all it takes is a simple, neutral detergent to remove dirt and restore it to its original splendour.



SALUBRE

Grazie alle sue caratteristiche fisiche la ceramica non rilascia alcuna sostanza nociva o VOC (sostanze organiche volatili) nell'ambiente in cui viviamo. Allo stesso modo non emette odori.

HEALTHY

Thanks to its physical characteristics, ceramic material does not release any harmful substances or VOC (volatile organic substances) into the environment we live in, nor does it give off odours.



RESISTENTE ALL'USURA Il gres porcellanato è un materiale tecnico ultra compatto, altamente resistente all'usura; sopporta bene calpestio, urti, graffi e carichi pesanti.

WEAR RESISTANT Porcelain stoneware is an ultra-compact technical material, extremely resistant to wear, tread, shock, scratching and heavy loads.

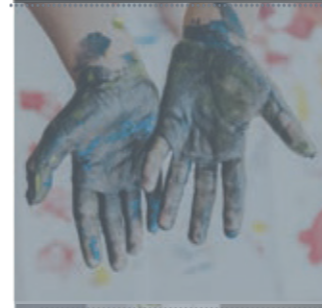

ANTIMACCHIA

La ceramica non teme macchie e non viene danneggiata con l'utilizzo di solventi e detersivi.

STAIN RESISTANT Ceramic material is resistant to stains and is not damaged by the use of solvents and detergents.

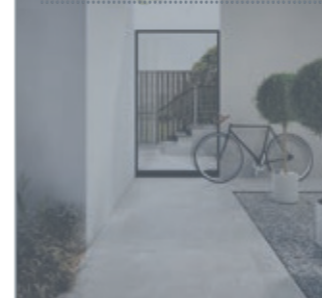

INGELIVA Il gres porcellanato resiste al gelo e tutti gli attacchi degli agenti atmosferici, ed è quindi il prodotto ideale anche in ambienti esterni.

FROSTPROOF Porcelain stoneware is resistant to frost and all kinds of attack from the elements, making it the ideal product also for outdoors.

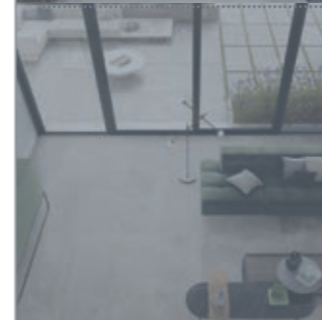

VERSATILE

La ceramica consente tante variazioni di stile e design, grazie all'ampia disponibilità di formati, spessori, e tinte. Inoltre può essere utilizzata in qualsiasi ambiente, sia a pavimento che a rivestimento, in interno o esterno, in ambienti residenziali o pubblici.

VERSATILE All sorts of style and design variants are possible with ceramics, thanks to the wide availability of different sizes, thicknesses, finishes and colours. It can also be used anywhere, on both floors and walls, indoors or outdoors, in residential or public settings.

Per maggiori informazioni visitate il sito www.ceramica.info e www.supergres.com

CERAMICHE
SUPERGRES

LA CERAMIC A. UNA SCELTA SICURA. CERAMICS. A SAFE CHOICE.

IGIENICA

La ceramica è facile da pulire, igienica e pratica; basta un semplice detergente neutro per rimuovere lo sporco e facilmente ritorna alla sua bellezza originaria.
Ceramic material is easy to clean, hygienic and practical; all it takes is a simple, neutral detergent to remove dirt and restore it to its original splendour.

HYGIENIC



SALUBRE

Grazie alle sue caratteristiche fisiche la ceramica non rilascia alcuna sostanza nociva o VOC (sostanze organiche volatili) nell'ambiente in cui viviamo. Allo stesso modo non emette odori. Il gres porcellanato è privo di PVC, plastiche o derivati del petrolio.
Thanks to its physical characteristics, ceramic material does not release any harmful substances or VOC (volatile organic substances) into the environment we live in, nor does it give off odours. Porcelain tiles contain no PVC, plastic or petroleum derivatives.

HEALTHY



RESISTENTE ALL'USURA WEAR RESISTANT

Il gres porcellanato è un materiale tecnico ultra compatto, altamente resistente all'usura; sopporta bene calpestio, urti, graffi e carichi pesanti. Porcelain stoneware is an ultra-compact technical material, extremely resistant to wear, tread, shock, scratching and heavy loads.



ANTIMACCHIA STAIN RESISTANT

La ceramica non teme macchie e non viene danneggiata con l'utilizzo di solventi e detersivi.
Ceramic material is resistant to stains and is not damaged by the use of solvents and detergents.



INGELIVA FROSTPROOF

Il gres porcellanato resiste al gelo e a tutti gli attacchi degli agenti atmosferici, ed è quindi il prodotto ideale anche in ambienti esterni.
Porcelain stoneware is resistant to frost and to all kinds of attack from the elements, making it the ideal product also for outdoors.



PRODOTTO NEL RISPETTO DELL'AMBIENTE ECO-SUSTAINABLE PRODUCTION

Il processo produttivo aziendale impiega un sistema di raccolta e di riutilizzo degli scarti di produzione, delle acque di lavorazione e del calore generato nelle fasi di produzione. In questo modo si limita il consumo di energia e di materie prime, per un'economia più sostenibile e un ridotto impatto ambientale.
The company's production process uses a system that collects and re-uses production waste, processing water and the heat generated during the production process, thus limiting the consumption of energy and raw materials, for a more sustainable economy and lower environmental impact.



RESISTENTE AI RAGGI UV: COLORI STABILI NEL TEMPO RESISTANT TO UV RAYS: LASTING COLOUR STABILITY

Esposta al sole anche per lungo tempo la ceramica non cambia colore, e mantiene inalterate nel tempo le sue caratteristiche estetiche e tecniche. Ceramic material does not fade even after lengthy exposure to sunlight, and maintains its aesthetic and technical characteristics over time.



PRODOTTO IGNIFUGO FIREPROOF

Resiste al fuoco e non emette fumi in seguito alla combustione.
Resistant to fire and does not emit smoke upon combustion.



IDEALE PER RISCALDAMENTO A PAVIMENTO IDEAL FOR UNDERFLOOR HEATING

Ottimo conduttore di calore, il gres porcellanato si riscalda rapidamente e il calore è rilasciato immediatamente nell'ambiente; in questo modo consente di mantenere limitate temperature d'esercizio dell'impianto di riscaldamento.
An excellent conductor of heat, porcelain stoneware warms up quickly and releases heat into the air immediately, making it possible to keep the heating system working temperatures lower.



VERSATILE VERSATILE

La ceramica consente tante variazioni di stile e design, grazie all'ampia disponibilità di formati, spessori, finiture e tinte. Inoltre può essere utilizzata in qualsiasi ambiente, sia a pavimento che a rivestimento, in interno o esterno, in ambienti residenziali o pubblici.
All sorts of style and design variants are possible with ceramics, thanks to the wide availability of different sizes, thicknesses, finishes and colours. It can also be used anywhere, on both floors and walls, indoors or outdoors, in residential or public settings.

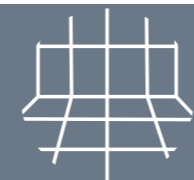

T.20

Per dettagli sul prodotto in 20 mm di spessore e sui relativi sistemi di posa ed, in particolare, per le raccomandazioni, accorgimenti, limitazioni di utilizzo e precauzioni in fase di posa, si raccomanda di prendere visione dell'ultima versione del catalogo T20 e del sito www.supergres.com

Pour de plus amples détails sur les produits de 20 mm d'épaisseur et sur leurs systèmes de pose, et en particulier; pour les recommandations, mises à jour, limitations d'usage et précautions en phase de pose, veuillez prendre connaissance de la dernière version du catalogue T20 et du site www.supergres.com

Für Details zum Produkt mit 20 mm Stärke und entsprechende Verlegesysteme, insbesondere hinsichtlich Hinweise und Anmerkungen, Nutzungseinschränkungen und Vorsichtsmassnahmen während der Verlegung, wird die Einsicht der letzten Version des Katalogs T20 und der Webseite www.supergres.com empfohlen.

For further details on the 20 mm product and the installation systems, in particular for recommendations, restrictions of use, and precautions during installation, please refer to www.supergres.com and to the latest release of T20 catalogue.

I dati e le informazioni riportate nel presente catalogo sono aggiornate al momento della stampa e potrebbero subire successive correzioni e/o modifiche. Verificare sempre l'ultima edizione disponibile confrontando la data riportata nell'ultima pagina della versione cartacea, con quella indicata nel pdf del catalogo scaricabile dal sito www.supergres.com

I colori e le caratteristiche estetiche dei prodotti sono indicativi e si avvicinano quanto più possibile a quelli reali nei limiti consentiti dai processi di stampa.

Data and information reported in this catalogue are updated at the moment of catalogue printing therefore they may be subject to subsequent corrections and/or amendments. Always check the latest available issue and compare the date reported on the last page of the hard-paper copy of the catalogue with that stated in the pdf. format downloadable on website www.supergres.com

The colours and aesthetic features of products are indicative and reproduce, as close as possible, the real colours and features taking into consideration the restrictions of printing processes.

© Copyright 2023 Ceramiche Supergres Casalgrande (Reggio Emilia) - Italy Pubblicato da Ceramiche Supergres. Strada Statale 467, n° 34 - 42013 Casalgrande (RE) Italy - Marzo 2019 Progetto, direzione e coordinamento a cura dell'ufficio marketing Ceramiche Supergres

© Copyright 2023 by Ceramiche Supergres Casalgrande (Reggio Emilia) - Italy Published by Ceramiche Supergres. Strada Statale 467, n° 34 - 42013 Casalgrande (RE) Ital - March 2019 Project, management and co-ordination by marketing Ceramiche Supergres

CERAMICHE
SUPERGRES

Finito di stampare a Modena (MO) nel mese di Aprile 2023 per conto di Ceramiche Supergres - Strada Statale 467, n° 34 - 42013 Casalgrande (RE) Italy I prodotti, i marchi e le immagini riprodotte nel presente catalogo sono tutelati ai sensi della normativa vigente in materia di proprietà intellettuale. Ogni violazione degli stessi verrà perseguita a norma di legge.

Printed in Modena (MO) in the month of April 2023 by on behalf of Ceramiche Supergres - Strada Statale 467, n° 34 - 42013 Casalgrande (RE) Italy All products, trade-marks and photographs reproduced in this catalogue are subject to all existing intellectual property laws. Any breach thereof will be dealt with under the provisions provided by such law.

